

**REGLER FOR NASJONALE
KLATREKONKURRANSER
2024-----**

**RULES FOR NORWEGIAN
CLIMBING
COMPETITIONS
2024-----**



NORGES KLATREFORBUND

Norwegian Climbing Federation

Ver 3.3

FORORD

Norges klatreforbund regelverk for nasjonale klatrekonkurranser, slik de her foreligger, er utarbeidet i samsvar med de gjeldende regler for internasjonale konkurranser (IFSC Europe og IFSC Rules). Det er imidlertid gjort tilpasninger til norske forhold.

I likhet med de internasjonale konkurransene, er også klatrekonkurranser i Norge i stadig endring. Derfor er dette reglement skrevet på engelsk og så langt det er mulig anpasset til IFSC:s reglement.

Dersom det skulle være uoverensstemmelse mellom dette dokumentet og European Cup og Youth Cup eller IFSC-reglementet, skal dette dokumentet være bestemmende. *Governance* delen av IFSC reglementet gjelder kun der dette anses som relevant av NKF og hoveddommer.

Norges klatreforbund
Pb 5000, 0840 Oslo
Email: klating@klating.no
www.klating.no

Versjon	Dato	Oppdateringer
3.3	18.09.2023	Reino Horak

Table of contents

<i>Norwegian Climbing Federation</i>	1
FORORD	1
Norwegian Cups and Championships	3
2 Competition organizers (with beginning 2023)	3
3 Competition Officials (with beginning 2023)	3
4 Norwegian Cup Lead and Para Lead (with beginning 2023)	4
5 Norwegian Cup Boulder (with beginning 2024)	4
6 Norwegian Cup Speed	6
7 Norwegian Championship Lead/Para (with beginning 2024)	6
8 Norwegian Championship Boulder (with beginning 2024)	6
9 Norwegian Championship Speed	7
10 Norwegian Championship Boulder & Lead (with beginning 2023)	7
11 General amendments for NKF competitions: (with beginning 2024)	7

Norwegian Cups and Championships

1 Introduction (with beginning 2023)

- 1) Norwegian Climbing Federation (NKF) has all rights and overall responsibility for the Norwegian Cup(s) and the Norwegian Championship(s).
- 2) All Norwegian Cup(s) and Norwegian Championship(s) shall be organized according to these rules and regulations
- 3) All Norwegian Cup(s) and Norwegian Championship(s) must comply to Norwegian laws, Antidoping regulations, Norwegian Olympic and Paralympic Committee and Confederation of Sports (NIF) rules and regulations.
- 4) Official result lists for competitions which have been published after the protest period has expired, cannot be changed afterwards, except by order from a higher judicial authority.

(Offisielle resultatlistene på konkurranser, som er publisert etter at protesttiden er utløpt, kan ikke endres i etterkant, utenom etter pålegg fra høyere domsmyndighet.)
- 5) In the case of exceptional circumstances, such as injunctions from authorities, other unforeseeable circumstances, logistic or broadcasting issues that arise, NKF has the right to change the format or other measures in relation to these regulations to be able to carry through national competitions.
- 6) Appeal National competitions,
The Complaints and Sanctions Committee (Klage og sanksjonsutvalget), deals with cases related to violations of the competition regulations during the implementation of national competitions organized by NKF.

2 Competition organizers (with beginning 2023)

- 1) NKF selects the organizer of Norwegian Cups, Norwegian Championships and Nordic Championships.
- 2) All competition organizers shall be an NKF affiliated club. In cases where this is not possible, the organizer of this competition shall be approved by the NKF board.
- 3) NKF reserve the right to enter and contract sponsor agreements in connection to competitions and can oblige the organizer to follow the obligations in the contract.

3 Competition Officials (with beginning 2023)

- 4) NKF appoints the Head Judge (hoveddommer) and if necessary, a NKF representant for national competitions.
- 5) The Head Judge (hoveddommer) has the same responsibility as the Jury President at international Climbing Competitions.
- 6) The NKF representant should during competitions have a supportive observer role with possibility to back up the organizer and head judge when needed or asked. The NKF representant is also responsible for making a written evaluation after the competition including feedback from, NKF, Organizer, Head judge, Routsetters and selected coaches.
- 7) In addition to Head Judge, there shall be one assisting judge (appointed by the head judge) and an adequate number of assistant routes, boulder, and speed judges. At least one judge per route/boulder. These judges are appointed by the organizer. When a Para competition simultaneously is held together with a lead competition there shall be an appointed judge by NKF for the Para part.

Competition format and amendments

4 Norwegian Cup Lead and Para Lead (with beginning 2023)

- 1) Competition Format according to the IFSC lead rules with the following amendments:
 - a) Competitions shall take place over two (2) rounds, qualification and final.
 - b) A qualification round of three (3) non-identical routes for each category. The routes may have different grades and character.
 - c) In the qualification round one starting group will be used per category
 - d) Minimum resting time between the qualification routes shall be 30 minutes

- 2) The ranking of competitors when three (3) qualification routes are used shall be in ascending order of the Total Points awarded to each competitor (i.e., lower Total Points is better), calculated according to the following formula

$$\sqrt[3]{R_1 \times R_2 \times R_3}$$

Where:

TP = Total Points

R_1 = Ranking Points on first Qualification route

R_2 = Ranking Points on second Qualification route

R_3 = Ranking Points on third Qualification route

5 Norwegian Cup Boulder (with beginning 2024)

- 1) The Contest Qualification format is a fixed period, unlimited attempts, "flash" format, conducted without demonstration.

Each boulder shall consist of one starting position, two (2) bonus holds and a top hold.

Unlimited attempts, one (1) point for reaching Bonus 1, two (2) additional points for reaching Bonus 2, seven (7) additional points for a top, two (2) additional bonus point if top is made on first attempt (flash).

To differentiate ties in qualification the order is a) number of tops, b) number of flash tops, c) number of bonus 2 d) number of bonus 1

The total amount of boulders set for the qualification should be 25, which shall be numbered from 1-25. Each course should consist of twenty (20) boulders.

The Jury president (hoveddommer) may in case of unforeseen and upcoming circumstances change the number of boulders in a course. The number of boulders of each course must never fall below 16 and the total amount of boulders must never fall below 21.

Approximate order of difficulty, e.g.

1	2	3	4	5	6	7	8	9	10	11	12	13	14	15	16	17	18	19	20	21	22	23	24	25
5	5	6	6	6	6	6	6	6	6	6	7	7	7	7	7	7	7	7	7	7	7	8	8	
c	c	a	a	a	b	b	b	c	c	c	a	a	a	a	b	b	b	b	c	c	c	a	b	

Example Climbing courses: U14/U16, U18 Fem, U20 & Sen. Fem - Climb boulder 1-20

U18 Male, U20 Male & Seniors Male - Climb boulder 6-25

This can be adjusted from the Head Judge according to level of climbers and difficulty of problems.

Climbing Time:

Number of competitors per climbing group	Climbing Time
0-30	120min (2h)
31-40	150min (2h 30m)
41-50	180min (3h)
+50	210min (3h 30m)

- e.g. *Group1 U14/U16 45 contenders. Climbing time 3h*
 Group 2 U18 Fem, U20 & Sen. Fem. 28 contenders. Climbing time 2h
 Group 3 U18 Male, U20 & Sen. Male, 40 contenders. Climbing time 2h 30min

Qualification:

- Que system same principal as 8 boulder flash jam session. (The athlete lines up and climbs as it becomes his turn on the boulder. Every athlete has only one (1) try. If he fails and wants to continue the same boulder, he must line up last in the que for the respective boulder).
- The start and end of the climbing time shall be announced by a loud signal.
- Contenders note themselves on their own scorecard plus digital tablet if such is available. (Self-scoring).
- **If one judge per boulder problem is attended the judge handles the scoring.**
- Except Head judge, there shall be minimum 5 controllers plus route setters during the qualification for assisting competitors, checking safety, climbing progression and prevent cheating.
- **Best alternative is having one judge on each boulder.**
- If a technical incident occurs affecting any boulder, they head judge shall close the affected boulder until the incident is cured.
- If the restoration time is less than or equal to 10 minutes, the affected boulder shall be re-opened and no additional time allocated. If the restoration time is more than 10 minutes, the relevant boulder shall be cancelled.

Finals:

- Finals will be held like in EYC & EC final format, which means an athlete will rotate through all boulders instead of all athletes trying one boulder after another. (See link European rules)
- The final quota consists of eight (8) contenders and the mode is **4 boulders/4 min + 15 sek** rotation time on sight with an 8 min total observation time.
- **The organizing venue must be able to conduct 8 finale boulders simultaneously.**
- The start and end of the climbing time shall be announced by a loud signal. The end of the round shall be preceded by a warning signal when one minute of time remains.
- Each final boulder shall consist of a starting position, one (1) bonus hold and a top hold. Each attempt is counted.

To differentiate ties in final the order is

- 1) Number of Tops,
 - 2) Number of Bonus
 - 3) Number of Top attempts,
 - 4) Number of Attempts for Bonus
 - 5) Countback to qualification.
- **It is mandatory that the final wall shall consist of at least 8 boulders for organiser to be able and run 2 classes simultaneously.**

6 Norwegian Cup Speed

- 1) Competition Format according to European Youth Cup speed rules.

7 Norwegian Championship Lead/Para (with beginning 2024)

- 1) Competition Format according to the IFSC lead rules with the following amendments:
 - a) Competitions shall take place over two (2) rounds, qualification and final. A semi-final round could be organized after approval by NKF.
 - b) In the qualification round one starting group will be used per category.
 - c) The Norwegian Championship in Para will be combined with an "Norwegian Nordic Para Invitational" competition. It's only allowed for Nordic citizens to participate and they don't need to be members of a Norwegian affiliated climbing club. Nordic participants will be able to win the competition but will not be able to win or get a rank in the Norwegian Championship.
 - d) Minimum resting time between the qualification routes shall be 30 minutes

8 Norwegian Championship Boulder (with beginning 2024)

- 1) **Competition Format when the championship is combined for juniors and seniors**

According to European rules. EYC and WC rules with the following modifications.

a) **Qualification:**

- b) According to EYC rules.
- c) Competitions shall take place over two (2) rounds, qualification and final.
- d) In the qualification, a qualification round in the flash mode consisting of two courses (A and B) of three (3) boulders for each Course and will be organized with one starting group.
- e) There shall be a minimum time gap of not less than 30 minutes between the completion of a competitor's final boulder on their first course (A or B) and commencing their second course. (A or B)

f) **Finals:**

Junior classes (U16, U18 & U20): According to EYC rules with a fixed final quota of eight (8) competitors.

Seniors: According to WC rules with a fixed final quota of six (6) competitors.

- 2) **Competition format with separate championships Junior & Senior:**

- a) **Junior:** Competitions shall take place over two (2) rounds according to EYC rules.
- b) **Senior:** NM boulder championships shall be organized over three (3) rounds for each category and shall be organized in the format specified in the IFSC Rules for WC competitions (IFSC-Rules 8.1) with following modifications:
 1. A Qualification round consisting of a single course of five (5) boulders for each Starting group with a respective fixed Semi-final quota of twenty (20) competitors
 2. A Semi-final and Final round in the mode of the IFSC-WC Series. A semi-final Mode consisting of a single course of four (4) boulders and 5 min climbing time, with a respective fixed Final quota of six (6) competitors and WC final format.
 3. If not more than 20 participants + 50% of a semi-final quota = total 30 athletes are registered, no semi-final will be held. There will only be a qualification and a final round. The registration deadline is relevant for the numbers of athletes per event.
 4. If the number of registered athletes (at the time of the Registration Deadline) is 20 or lower than the fixed quota of 20 – the qualification round can be skipped.

9 Norwegian Championship Speed

- 1) Competition Format according to European Youth Cup speed rules.

10 Norwegian Championship Boulder & Lead (with beginning 2023)

1. Competition Format according to IFSC OL-Combined rules with following amendment.
 - a) The rank for each discipline is added to select the winner. If there is a tie within the top 3 (gold, silver, or bronze) the IFSC ranking points (see below) from each discipline should be added. If there still are tied places, individual performance (best rank position) shall determine the winner. As third, highest low rank position in one of the disciplines shall determine.
 - b) *If there is no separate B&L event the general qualification result from NM in boulder & lead should be calculated as above in a). Only participants competing in both disciplines are accounted for.
 - where no combined Boulder & Lead competition in the Combined Discipline is held, a combined Boulder & Lead ranking will be calculated from the General Qualification Rankings for the competitions in the Boulder and Lead disciplines, assigning ranking points as set out at Annex below (Cup Ranking Points) to each set of results. A points total will be calculated for each competitor participating in both Boulder and Lead disciplines and these competitors will be ranked in descending order of the total points awarded and the ranking published.

RANK	POINTS	RANK	POINTS	RANK	POINTS	RANK	POINTS
1	1000	16	220	31	42	46	10
2	805	17	205	32	37	47	9
3	690	18	185	33	33	48	9
4	610	19	170	34	30	49	8
5	545	20	155	35	27	50	8
6	495	21	145	36	24	51	7
7	455	22	130	37	21	52	7
8	415	23	120	38	19	53	7
9	380	24	105	39	17	54	6
10	350	25	95	40	15	55	6
11	325	26	84	41	14	56	6
12	300	27	73	42	13	57	5
13	280	28	63	43	12	58	5
14	260	29	56	44	11	59	5
15	240	30	48	45	11	60	4

11 General amendments for NKF competitions: (with beginning 2024)

- 1) All participants must be member of an NKF affiliated climbing club. In case NKF organize an open Para Climbing Competition, membership of an NKF affiliated climbing cup is not mandatory for Nordic citizens, only Norwegian citizens have to be member of an NKF affiliated climbing club.
- 2) For Norwegian Championships: Participants must possess a Norwegian citizenship or have lived with an official registered address in Norway the last twelve (12) months to participate (except for Nordic citizens attending the Norwegian Nordic Para Invitational).
- 3) For Norwegian Cups, other foreign citizens may participate. If they reach the final, the number of finalists shall increase accordingly.
If the number of finalists exceeds three (3) more than the nominal number, the Jury President may:
 - a) Reduce the number of foreign citizens in the final
 - b) Exclude the last tied competitors from the final
 - c) The above is not applicable for open para climbing competitions.

- 4) On Norwegian championships and Norwegian cups, the participant climbers represent their climbing club. These climbers shall therefore wear clothing showing club representation. The climbing club is responsible for their climbers representing the club in the correct clothing. If not wearing a club clothing it shall render a yellow card from the head judge. In case of repeated use of not approved clothing the athlete shall retain a red card from the head judge.
- 5) NKF have the right to put a quota for the number of foreign participants outside the official competition.
- 6) At NC competitions, everyone must compete in the age group they belong to. At NM competitions, competitors from U18 are eligible to register in the senior category.
- 7) Age categories in the competitions are defined according to the following table:

Table 1: Age categories according to birth year,

Competition	½ U14	U16	U18	U20	Senior
From 2023 NC and NM	Competitors who will be 13 in the year of the competition (2010)	Competitors who will be 14 or 15 years in the year of the competition (2009 & 2008)	Competitors who will be either 16 or 17 years in the year of the competition (2007 & 2006)	Competitors who will be either 18 or 19 years in the year of the competition (2005 & 2004)	Competitors who will be 20 years in the year of the competition (2003)
From 2024 NC and NM	Competitors who will be 13 in the year of the competition (2011)	Competitors who will be 14 or 15 years in the year of the competition (2010 & 2009)	Competitors who will be either 16 or 17 years who will be the year of the competition (2008 & 2007)	Competitors who will be either 18 or 19 years in the year of the competition (2006 & 2005)	Competitors who will be 20 years in the year of the competition (2004)

At NC competitions, everyone must compete in the age group they belong to. At NM competitions, competitors from U18 are eligible to register in the senior category.

- 8) Randomize starting order for finalists with tied results from previous rounds.
- 9) Official video recording is not mandatory in qualification rounds.
- 10) The Norwegian Cup shall have a minimum of three (3) competitions during a competition year/season in each discipline boulder and lead, including the Norwegian Championship. If they are 3 separate NC competitions/discipline the NM shall not be included in the overall Cup aggregation.
 - a) The ranking in the overall Norwegian Cup (Norgescup sammenlagt) is calculated by adding IFSC ranking points.
 - b) An overall cup winner (Only the No.1 male and female in each age group) for Norwegian cups in boulder and lead combined will be announced after the last cup competition included for the season. A competitor must have participated in a minimum of three (3) out of the six (6) competitions in the same competition season and in both disciplines, to be ranked for the final Norwegian Cup ranking. The best two (2) boulder results and the best two (2) lead results will be calculated to determine the overall cup winner.

- c) The best participating clubs at overall Norwegian cups will be awarded after the last Norwegian cup competition for the season. A challenge prize (vandrepopokal) will rotate through the years for the No.1 winning club. Additional predesigned medals will be awarded for the top 3 podium clubs every year after finished competition season. The top three (3) winning clubs will be calculated by adding IFSC ranking points for the best four (4) results from two (2) boulder cups and two (2) lead cups. The best three athlete performances in each of the 4 calculated competitions will be counted.

If there is a tie within the top 3 (gold, silver, or bronze), individual performance (best rank position) shall determine the winner. Secondly, highest low rank position in one of the disciplines shall determine. If there still is a tie the clubs will share the spot and share the time of the challenge prize (vandrepopokal) until the following year.

IFSC ranking points

RANK	POINTS	RANK	POINTS	RANK	POINTS	RANK	POINTS
1	1000	16	220	31	42	46	10
2	805	17	205	32	37	47	9
3	690	18	185	33	33	48	9
4	610	19	170	34	30	49	8
5	545	20	155	35	27	50	8
6	495	21	145	36	24	51	7
7	455	22	130	37	21	52	7
8	415	23	120	38	19	53	7
9	380	24	105	39	17	54	6
10	350	25	95	40	15	55	6
11	325	26	84	41	14	56	6
12	300	27	73	42	13	57	5
13	280	28	63	43	12	58	5
14	260	29	56	44	11	59	5
15	240	30	48	45	11	60	4

11) The registration fee for each participant in a Norwegian Cup or Championship is:

- a) 350 NOK for one discipline (boulder, lead or para) in Norwegian Cups.
- b) 500 NOK for one discipline (boulder, lead or para) in Norwegian Championships.
- c) 250 NOK additional fee for a combination of lead & speed, boulder & speed, or boulder & lead.
- d) Maximum 750 NOK for a cup or championship with Boulder & Lead combined or with all three disciplines (Boulder, Lead & Speed).

12) The appeal fee is 250 NOK.

13) Classification Para:

- a) See point 14 below
- b) Open class for physical impairment (mental impairment is not included)

14) Participant rules for Norwegian Cups & Championships

Para:

- If less than 6 participants, the organiser may cancel the competition. (Deadline for registration counts)
- At competitions para climbers register as para climber with their classification. After registration deadline para classification will be done according to IFSC classification and an adapted IFSC merging system. Every registered para climber however must have a classification at the registration.
- If less than 2 participants in a category, classes will be merged according to an adapted IFSC merging system (Registered athletes counts). Merging preferable but not mandatory between genders inside same para category.

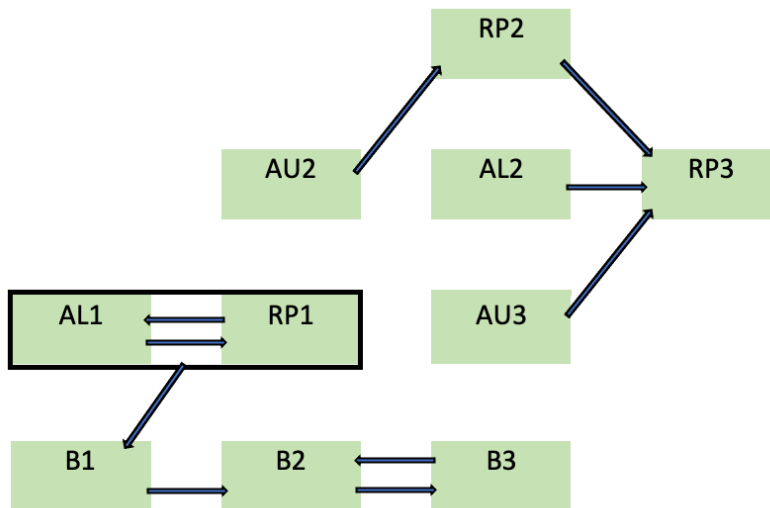

Sport classes physical impairment:

Amputees

- AU2: Moderate Upper Limb impairment - One upper limb has reduced function below the athlete's elbow and does not have a functional wrist joint.
- AU3: Hand impairment - One hand or multiple digits across both hands are absent or have reduced function
- AL1: Bilateral Lower Limb impairment - Significantly reduced functional use for climbing or absence of bilateral lower limbs.
- AL2: Unilateral Lower Limb impairment or leg length difference - Impairment in a single lower limb.

Limited reach, power or stability

- RP1: "Range, Power" severe impairment, inclusive of other impairment types - Impairment across all eligible impairment types with severe impairment to function affecting at least 2 limbs or a single upper limb is absent or has severely limited functional use.
- RP2: "Range, Power" moderate impairment, inclusive of other impairment types - Impairment across all eligible impairment types with moderate impairment to function affecting the trunk and/or limbs.
- RP3: "Range, Power" mild impairment, inclusive of other impairment types - Impairment across all eligible impairment types with mild impairment to function affecting the trunk and/or limbs.

Blind sport classes

- Sport Class B1
Visual acuity is poorer than LogMAR 2. 60.
- Sport Class B2
Visual acuity ranges from LogMAR 1. 50 to 2. 60 (inclusive), and/or the visual field is constricted to a radius of less than 10 degrees diameter.
- Sport class B3 Visual acuity ranges from LogMAR 1. 40 to 1 (inclusive), and/or the visual field is constricted to a radius of less than 40 degrees diameter.

Able-bodied:

- d) If less than 70 participants, the organiser may cancel the competition. (Deadline for registration counts)

15) Medals for the different competitions

- a) For Norwegian championships predesigned NM medals by NKF should be used for all disciplines and categories.
- b) For Norwegian Cups organiser or NKF may choose design of medals individually for each competition.
- c) For overall Cup winner (only No.1 male and female), a predesigned medal or plaque by NKF should be used.
- d) For overall Club cup winners there shall be a challenge prize (vandrepopokal) for the No.1 club plus 3 predesigned medals or plaques for the top three clubs.

16) Other amendments

- a) Deadline for registration, 2 weeks before competition registration day
- b) An extra registration fee of 200 NOK will be charged for participants that register between 2 weeks and 1 week (13 days and 7 days) before competition registration day
- c) NKF is only responsible for streaming the finals at the NM and Nordic championships held in Norway. NKF will however work for the possibility that external streaming players can stream other national competitions.

Lenke seneste IFSC & IFSC-EU reglement.

IFSC-EU reglement ligger under «Dokumenter» nede på siden.

IFSC RULES 2024 - <https://www.ifsc-climbing.org/resources/rules>

IFSC EUROPE RULES 2024 - <https://www.ifsc-climbing.org/europe/index>